

GUIDE POSTS FOR DIE SETS
ダイセット用ガイドポスト

RoHS 10

—着脱ポスト—



MRP
(可動ストップ\STM用)

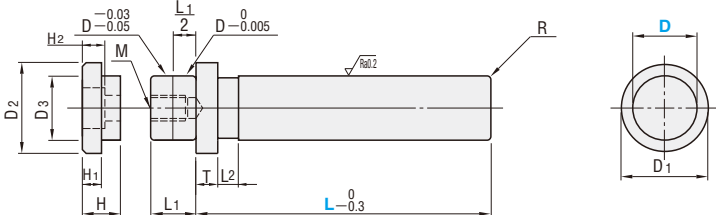

BRPM
(可動ストップ\STM用)

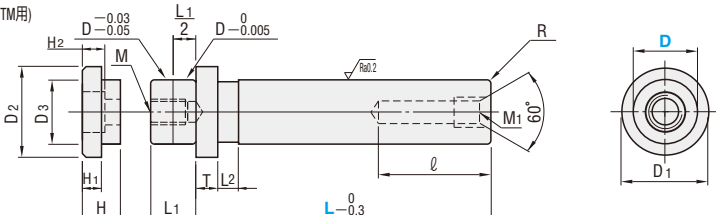

BRPK
(固定ストップ\STK用)

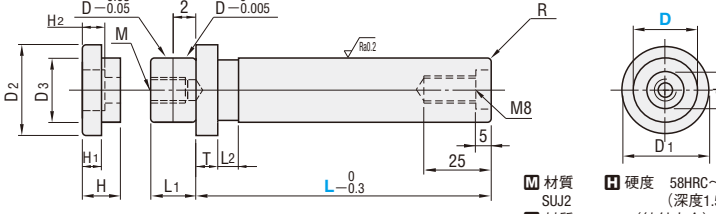

材質 SUJ2 硬度 58HRC～高周波焼入 (深度1.5～2.0mm)
 材質 S45C (締付座金)

RoHS 10

—圧入ポスト—



MSP

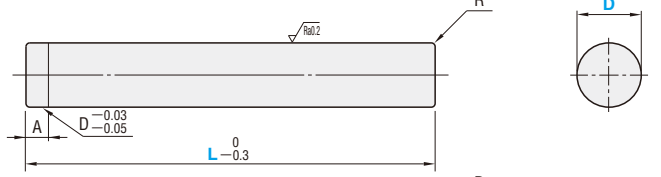

BSPM
(可動ストップ\STM用)

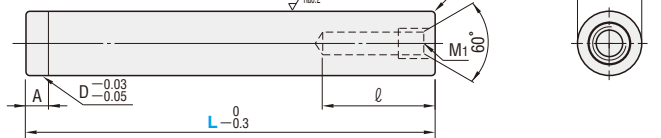

BSPK
(固定ストップ\STK用)

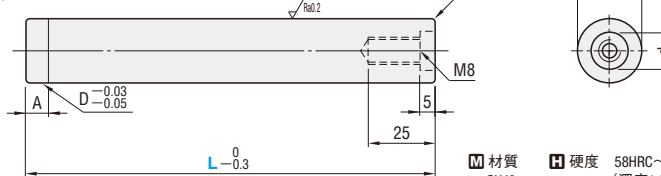

材質 SUJ2 硬度 58HRC～高周波焼入 (深度1.5～2.0mm)

D	D ₁	T	L ₁	L ₂	ℓ	M ₁ ×P	d	A	M	R	D ₂	D ₃	H	H ₁	H ₂	付属ボルト
20	+0.020	29	5	15	38	M10×1.5	14	4	M8×18	2.0	28	19.5	14	7	8.5	CB 8-25
22	+0.015	31	8	16							42	30				
25		36		18	50	M12×1.5	20	5	M10×22	3.5	35	24.5	16	8	10.5	CB10-30
28	+0.025	39	10	20							36	27.5				
32	+0.020	44		23	60	M16×1.5	20	6	M12×27	4.0	40	31.5	18	10	12.5	CB12-35
38	+0.030	53	12	27							49	37.5				
45	+0.025	59		32	70	M16×1.5	20	7	M14×31	5.0	55	44.5	20	12	14.5	CB14-40
50	+0.035	69	15	35							62	49.5				
60	+0.030	79		42							72	59.5				

●ガイドポストの取付穴加工についてはP.1104を参照ください。

●ボルトは締付座金に付属します。

型式 Type	D	L											
		MRP	20	80	90	100	110	120					
BRPM	22	80	90	100	110	120							
	25	80	90	100	110	120	130						
BRPK	28			100	110	120	130	140	150	160			
	32					120	130	140	150	160			
	38							140	150	160	170	180	
	45								140	150	160	170	180
	50									160	170	180	200
	60										160	170	180

型式 Type	D	L													
		MSP	20	100	110	120	130	140	150	160	170	180			
BSPM	22			120	130	140	150	160	170	180					
	25			120	130	140	150	160	170	180					
BSPK	28					140	150	160	170	180	190	200			
	32							160	170	180	190	200	220	240	
	38								180	190	200	220	240	260	
	45									180	190	200	220	240	260
	50										200	220	240	260	
	60											200	220	240	260

Order 注文例: 型式 **MRP 20** - L(LC) **LC77**

Delivery 出荷日: 在庫品

Alterations 追加加工: 3 日目出荷, ストックT, ストックA

●全長ロング指定ガイドポストは P.1119に掲載しています。

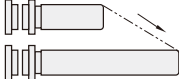

追加工	記号	詳細				
		1mm単位指定				
		D	MRP	BRPM・BRPK	MSP	BSPM・BSPK
MRP・BRPM・BRPK	LC	20	60 ~ 119	70 ~ 119	70 ~ 179	80 ~ 179
		22	60 ~ 119	70 ~ 119	70 ~ 179	80 ~ 179
MSP・BSPM・BSPK	LC	25	60 ~ 129	80 ~ 129	70 ~ 179	80 ~ 179
		28	60 ~ 159	80 ~ 159	70 ~ 199	80 ~ 199
		32	60 ~ 159	100 ~ 159	70 ~ 239	80 ~ 239
		38	60 ~ 179	100 ~ 179	70 ~ 259	80 ~ 259
		45	60 ~ 179	120 ~ 179	70 ~ 259	90 ~ 259
		50	60 ~ 199	120 ~ 199	70 ~ 259	90 ~ 259
		60	60 ~ 199	120 ~ 199	70 ~ 259	90 ~ 259

ダイセット用
ガイドポスト・フィンシュ