

# アンギュラ穴付ロックブロック

幅省スペースタイプ P564

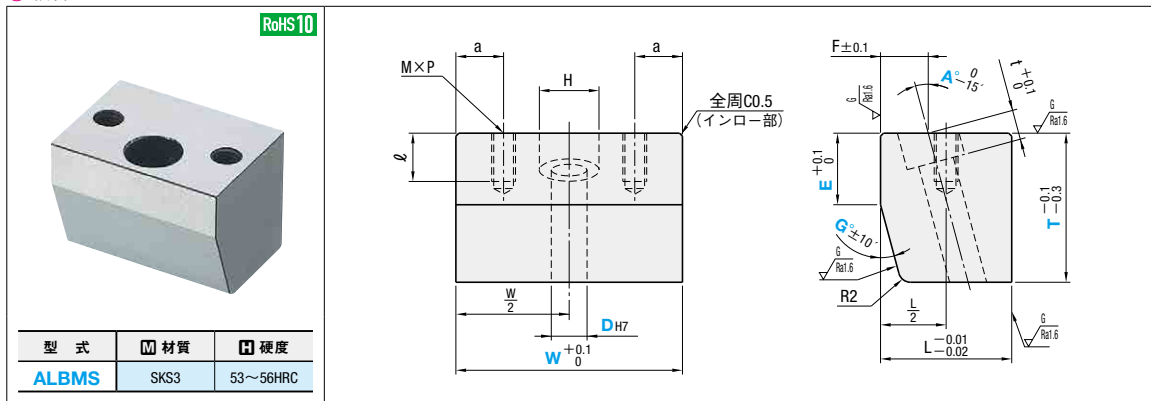

型式	材質	硬度
ALBMS	SKS3	53~56HRC

D <sub>H7</sub>	H	F	ℓ	M×P	t	a	L	型式		W	E 指定1mm単位	指定1°単位	
								Type	D			A°	G°
6	+0.012 0	10	6	8	4×0.7	5	5	20	ALBMS	6	20	10~20	G ≥ A+2 and G ≤ A+5
											22		
											25		
											30		
											35		
8	+0.015 0	12	8	12	6×1.0	5	6	25	8	20	38 48 58	10~13	10~20
										26			
										30			
										35			
10	+0.015 0	14	10	16	8×1.25	10	7	32	10	35	38 48 58 68	10~15	10~20
										36			
										40			
										50			
										55			
13	+0.018 0	17	12	16	8×1.25	10	8	40	13	40	48 58 68 78	10~20	10~20
										45			
										50			
										60			

Order 注文例: 型式 - T - W - E - A - G  
ALBMS6 - T25 - W48 - E11 - A15 - G17

Delivery 出荷日: 8 日日出荷, ストック C

Alterations 追加加工: 型式 - T - W - E - A - G - (CC)  
ALBMS10 - T35 - W48 - E12 - A18 - G20 - CC

追加加工	記号	詳細
4×C	CC	外周(W・L)コーナー 4ヶ所のC面取加工
		D C
		6 3
		8 3
		10 5
		13 5

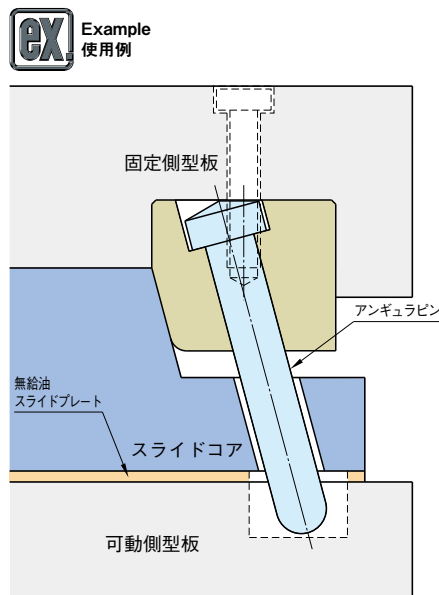

# アンギュラ穴付ロックブロック

-PL面取付タイプ-

幅省スペースタイプ P564

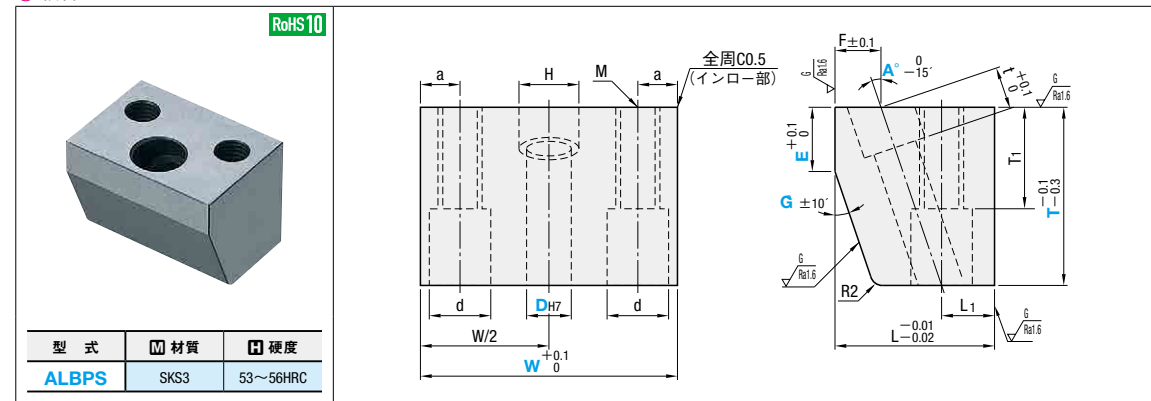

型式	材質	硬度
ALBPS	SKS3	53~56HRC

D <sub>H7</sub>	H	F	t	T <sub>1</sub>	d	M	a	L <sub>1</sub>	L	型式		W	E 指定1mm単位	指定1°単位	
										Type	D			A°	G°
10	+0.015 0	14	10	10	14	10	9	12	32	ALBPS	10	30	48 58 68	10~20	G ≥ A+2 and G ≤ A+5
												35			
												40			
												50			
												60			
13	+0.018 0	17	12	10	14	10	9	14	40	13	35	48 58 68 78	10~20	10~20	
											40				
											50				
											60				
											78				
16	+0.018 0	20	15	13	25	17	12	12	50	16	35	58 68 78	10~20	10~20	
											40				
											50				
											60				
											78				
20	+0.018 0	24	15	13	30	14	10	9	55	20	40	58 68 78	10~20	10~20	
											50				
											60				
											78				

Order 注文例: 型式 - T - W - E - A - G  
ALBPS10 - T30 - W58 - E12 - A15 - G17

Delivery 出荷日: 8 日日出荷, ストック C

Alterations 追加加工: 型式 - T - W - E - A - G - (CC)  
ALBPS13 - T40 - W68 - E15 - A18 - G20 - CC

追加加工	記号	詳細
4×C5	CC	外周(W・L)コーナー 4ヶ所にC5の面取加工

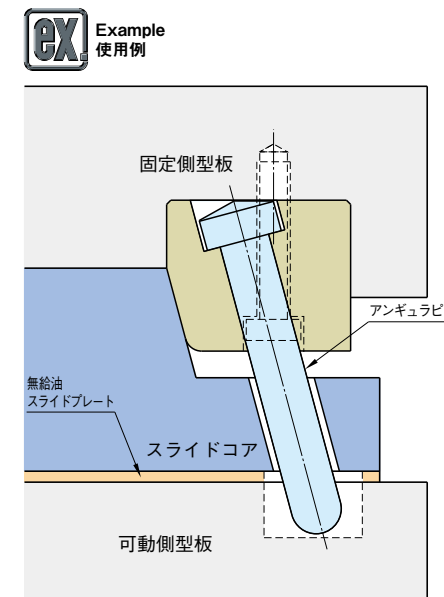

アンギュラピン  
ロックブロック