

インローコアピン

-軸径(P)指定タイプ-

追加加工価格も数量スライド適用 P.49

Type	材質	硬度	Group	公差 P		公差 L		公差 F		公差 A		公差 V		公差 Ks	
				Step A	Step B・C・D・E	Step A	Step B・C・D・E	Step A	Step B・C・D・E	Step E	Step C・D	Step C・D	Step C・D		
				標準	精級	標準	精級	標準	精級	標準	精級	標準	精級		
CPDB-2	SKD61	48~52HRC	標準	-0.01 +0.02	+0.02 0	+0.05 0	+0.02 0	±0.015		±0.015		±0.015		45° ±1°	
CPPB-2	SKD61	48~52HRC	標準		+0.02 0		+0.02 0	±0.01		±0.02		±0.01			
CPHB-2	SKH51	58~60HRC	標準		+0.02 0		+0.02 0	±0.01		±0.02		±0.01			
CPVB-2	SKH51	58~60HRC	精級	0 -0.005	+0.01 0	+0.05 0	+0.01 0	±0.005		±0.005		±0.005		45° ±30'	

Order 注文例: 型式 - L - P - F - A - V - S - C・R - B
 CPDB-2D5 - 35.00 - P4.75 - F23.00 - A4.60 - V4.00 - S3.00 - C0.5 - B5.0

Delivery 出荷日: 3 日日出荷
 注文締切: ストック T 当日出荷 1,000円/本 正午迄
 ストック A 翌日出荷 500円/本 PM 6:00迄
 ①ストックAは3本以上で1明細行当たり一律1,350円

Price 価格: 数量スライド価格 (①1円未満切り捨て) P.47

数量区分	標準対応	個別対応大口			
数量	1~4	5~12	13~19	20~50	51~
値引率	基準単価	5%	10%	15%	お見積り

②表示数量超えはWOSIにてご確認ください。

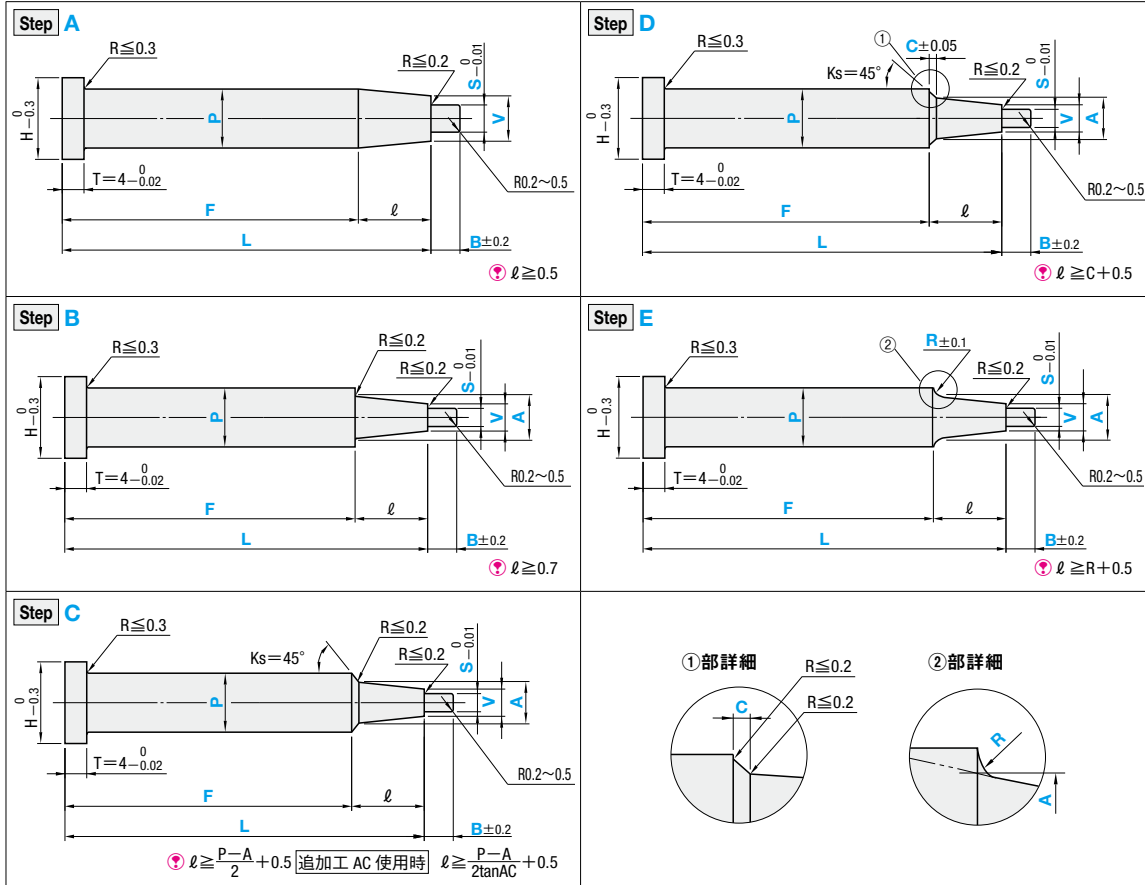

H	型式	Step No.	指定0.01mm単位 (精級P寸法指定0.005mm単位)		指定0.1mm単位		L max.		
			標準	精級	P	F		A	V
3	CPDB-2	1.5	L ≥ 12.00	L ≥ 22.00	1.00 ~ 1.495	標準	20.00		
4		2	and	and	1.50 ~ 1.995			0.50	25.00
5		2.5	and	and	2.00 ~ 2.495				
6	CPDB-2	3	L ≤ 100.0-B	L ≤ 100.0-B	2.50 ~ 2.995	標準	35.00		
7		3.5	and	and	3.00 ~ 3.495			1.00	40.00
8	CPPB-2	4	L ≥ 12.00	L ≥ 22.00	3.50 ~ 3.995	標準	45.00		
9		4.5	and	and	4.00 ~ 4.495			1.50	50.00
10	CPHB-2	5	L ≤ 120.0-B	L ≤ 120.0-B	4.50 ~ 4.995	標準	50.00		
11		5.5	and	and	5.00 ~ 5.495			2.00	50.00
15	CPVB-2	6	P16.00~19.99		5.50 ~ 5.995	精級	50.00		
18		6.5	L ≥ 30.00		6.00 ~ 6.495			2.50	50.00
21		7	L ≤ 120.0-B		6.50 ~ 6.995	標準	50.00		
25		8	and		7.00 ~ 7.995			3.00	50.00
		10	L ≤ 120.0-B		8.00 ~ 9.995	精級	50.00		
		13			10.00 ~ 12.995			2.50	50.00
		16			13.00 ~ 15.995	3.00	50.00		
		20			16.00 ~ 19.995			5.00	50.00

¥基準単価 1~4本

Type	CPDB-2					CPPB-2 CPHB-2					CPVB-2				
No. Step	A	B	C	D	E	A	B	C	D	E	A	B	C	D	E
1.5	2,310	2,480	2,750	2,910	3,330	2,990	3,170	3,420	3,580	4,000	4,490	4,740	5,130	5,380	6,010
2	2,310	2,480	2,750	2,910	3,330	2,990	3,170	3,420	3,580	4,000	4,490	4,740	5,130	5,380	6,010
2.5	2,110	2,260	2,490	2,650	3,030	2,720	2,880	3,110	3,260	3,640	4,090	4,310	4,660	4,900	5,460
3	2,110	2,260	2,490	2,650	3,030	2,720	2,880	3,110	3,260	3,640	4,090	4,310	4,660	4,900	5,460
3.5	2,150	2,300	2,530	2,680	3,060	2,760	2,920	3,150	3,290	3,690	4,150	4,380	4,680	4,950	5,540
4	2,150	2,300	2,530	2,680	3,060	2,760	2,920	3,150	3,290	3,690	4,150	4,380	4,680	4,950	5,540
4.5	2,190	2,340	2,570	2,720	3,110	2,840	2,990	3,210	3,370	3,750	4,260	4,480	4,820	5,060	5,630
5	2,190	2,340	2,570	2,720	3,110	2,840	2,990	3,210	3,370	3,750	4,260	4,480	4,820	5,060	5,630
5.5	2,240	2,390	2,630	2,780	3,170	2,930	3,080	3,320	3,460	3,850	4,390	4,620	4,980	5,200	5,770
6	2,240	2,390	2,630	2,780	3,170	2,930	3,080	3,320	3,460	3,850	4,390	4,620	4,980	5,200	5,770
6.5	2,280	2,430	2,680	2,820	3,200	3,040	3,200	3,420	3,570	3,950	4,560	4,790	5,130	5,360	5,940
7	2,280	2,430	2,680	2,820	3,200	3,040	3,200	3,420	3,570	3,950	4,560	4,790	5,130	5,360	5,940
8	2,330	2,560	2,720	2,940	3,330	3,340	3,490	3,720	3,870	4,260	5,000	5,230	5,580	5,810	6,380
10	2,680	2,840	3,060	3,210	3,530	3,660	3,810	4,040	4,190	4,580	5,480	5,720	6,070	6,210	6,860
13	3,150	3,320	3,600	3,770	4,140	5,130	5,330	5,660	5,880	6,410	7,680	8,000	8,500	8,810	9,600
16	3,700	3,920	4,230	4,440	4,870	5,860	6,090	6,460	6,710	7,330	8,780	9,150	9,700	10,070	10,980
20	6,980	7,390	7,980	8,370	9,190	7,130	7,540	8,140	8,540	9,560	9,000	9,620	10,570	11,220	12,770

Alterations 追加加工: 型式 - L - P - F - A - V - S - C・R - B - (KC・WKC...etc.)
 CPDB-2C5 - 35.00 - P4.75 - F23.00 - A4.40 - V4.00 - S3.00 - B5.0 - RKC2.4

追加加工詳細 P.535

Alterations	Code	Spec.	¥/Code
	KC	1面ツバカット P/2 ≤ KC < H/2	100
	WKC	2面ツバカット P/2 ≤ WKC < H/2	200
	KAC KBC	寸法違いツバカット P/2 ≤ KAC < H/2 KBC = 指定0.1mm単位のみ KAC < KBC < H/2	300
	RKC	2面(直角)ツバカット P/2 ≤ RKC < H/2	200
	DKC	3面ツバカット P/2 ≤ DKC < H/2	300
	SKC	4面ツバカット P/2 ≤ SKC < H/2	400
	KGC	2面ツバカット(角度) P/2 ≤ KGC < H/2 AG = 指定1°単位 0 < AG < 360	300
	KTC	3面ツバカット 120°振分け P/2 ≤ KTC < H/2	400

Alterations	Code	Spec.	¥/Code
	HC	ツバ径変更 HC = 指定0.1mm単位 P ≤ HC < H	200
	HCC	ツバ径変更(精密) HCC = 指定0.1mm単位 P + 0.5 ≤ HCC < H - 0.3	400
	TC	ツバ厚変更 TC = 指定0.1mm単位 1.5 ≤ TC < 4 (L寸法は指定寸法通り) 4 - TC ≤ Lmax - L	200
	AC	標準Ks=45°を角度指定可 AC = 指定1°単位 ① 30 ≤ AC ≤ 60 ② [Step] C・Dに適用 ③ [Step] Dの場合 C ≤ 1.0 A + 2 (C × tanAC°) < P	400
	TRN	ツバ下の逃げ加工 (プレートの面取が不要)	100
	NHC	ツバ裏ナンバリング加工 指定範囲・方法は P.536 ① ストック適用不可 ② SKC併用不可 ③ H ≥ 2に適用	(1-2文字) 50 (3文字) 100
	GVC	ガスベント加工 GS・GB = 指定1mm単位 ① 2 ≤ GS ≤ 10 GS + 2 ≤ GB ≤ 30 Fmin ≤ F - GB ② P ≥ 2.00に適用 指定方法は P.536	600