



TENSION SPRINGS -MEDIUM TO HEAVY・HEAVY LOAD TYPE-

引張りばね

—中重荷重・重荷重タイプ—



□:値下げ価格
□:新価格
□:スライド値引率変更



CADデータフォルダ名: 37_Springs

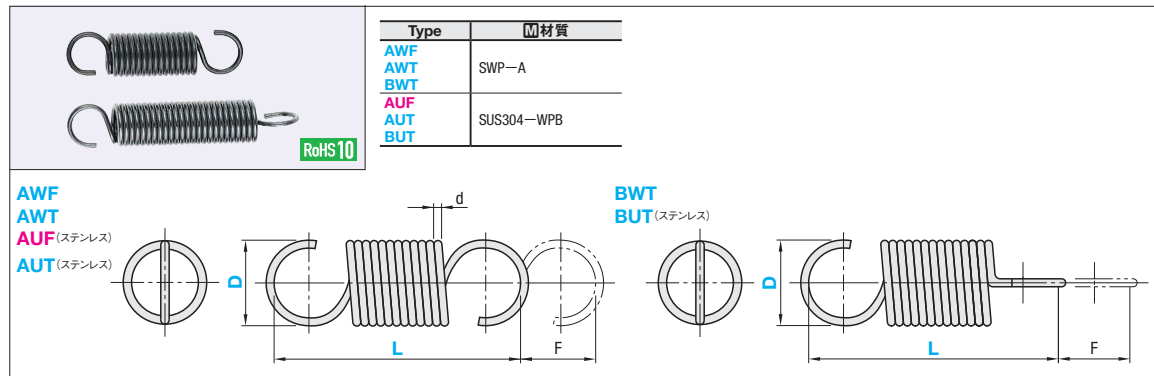

Type	材質
AWF AWT BWT	SWP-A
AUF AUT BUT	SUS304-WPB



■中重荷重タイプ

Type	D-L	線径 dmm	動荷重の場合		初張力 N (参考値)	ばね定数 N/mm (参考値)	¥基準単価	
			最大荷重 N	最大荷重 N			AWF	AUF
AWF AUF	3-10	0.45	2.2	6.47	1.57	2.26	170	290
	15		4.5	1.08				
	20		6.7	0.74				
	25		9.1	0.54				
	30		11.4	0.43				
AWF AUF	4-15	0.55	4.5	8.43	1.86	0.93	190	310
	20		7.1	0.66				
	25		10.0	0.52				
	30		12.6	0.43				
	35		15.2	0.36				
AWF AUF	5-15	0.7	3.9	14.71	2.45	1.77	200	320
	20		6.9	1.28				
	25		9.6	0.98				
	30		12.5	0.78				
	35		15.6	0.64				
AWF AUF	6-20	0.9	3.9	23.54	5.88	4.51	210	340
	25		6.0	2.94				
	30		7.8	2.26				
	35		10.0	1.77				
	40		12.0	1.47				
AWF AUF	8-25	1.1	5.8	31.38	6.86	4.23	220	360
	30		8.3	2.94				
	35		10.9	2.26				
	40		13.2	1.86				
	45		15.6	1.57				
AWF AUF	10-30	1.4	6.5	49.03	12.75	5.58	370	580
	35		8.7	4.17				
	40		10.7	3.39				
	45		12.9	2.81				
	50		15.2	2.39				
AWF AUF	12-35	1.8	5.0	83.36	23.54	12.0	410	740
	40		7.0	8.55				
	45		9.0	6.65				
	50		11.0	5.44				
	55		13.0	4.60				

Type	D-L	線径 dmm	動荷重の場合	初張力 N (参考値)	ばね定数 N/mm (参考値)	¥基準単価
			最大荷重 N			AWF
AWF	14-40	2.1	5.9	110.42	31.74	540
	45		7.3	10.79		
	50		8.7	9.06		
	55		10.7	7.31		
	60		12.1	6.47		
	65		14.2	5.52		
	70		15.6	5.03		
	75		17.0	4.62		
	80		19.1	4.12		
	90		22.5	3.48		
AWF	16-45	2.4	5.8	141.22	41.45	640
	50		7.3	17.26		
	55		9.6	13.62		
	60		11.1	10.35		
	65		12.7	8.93		
	70		14.3	7.84		
	75		15.8	7.00		
	80		17.3	6.31		
	90		20.4	5.75		
	100		23.5	4.88		
AWF	18-50	2.6	7.1	160.70	44.53	740
	55		9.0	16.37		
	60		10.9	12.92		
	65		12.8	10.68		
	70		14.7	9.09		
	75		16.6	7.92		
	80		18.5	7.02		
	90		22.2	6.30		
	100		26.0	5.22		
	125		34.6	4.46		
AWF	20-60	3.0	8.8	214.62	64.77	990
	70		11.6	17.03		
	80		14.4	12.94		
	90		18.1	10.44		
	100		20.9	8.30		
	125		28.3	7.19		
	150		36.6	5.30		
	175		44.0	4.10		
	200		44.0	3.41		
	AWF		24-80	3.5	12.6	
90		15.8	14.90			
100		18.0	11.79			
125		25.7	9.77			
150		33.3	8.98			
175		40.9	6.98			
200		48.6	5.43			
					4.44	
					3.76	



●D8以下
■数量スライド価格 (1円未満切り捨て) P.133

数量区分	標準対応			個別対応
	小口	大口	大口	
数量	1~19	20~34	35~199	200~400
値引率	20%	30%	30%	30%
出荷日	通常	通常	+6日	お見積り

◎表示数量超えはWOSにてご確認ください。

●D10以上
■数量スライド価格 (1円未満切り捨て) P.133

数量区分	標準対応			個別対応
	小口	大口	大口	
数量	1~19	20~34	35~199	200~400
値引率	20%	30%	30%	30%
出荷日	通常	通常	+9日	お見積り

◎表示数量超えはWOSにてご確認ください。

■重荷重タイプ *印はAWT・AUTのみです。

Type	D-L	線径 dmm	動荷重の場合		初張力 N (参考値)	ばね定数 N/mm (参考値)	¥基準単価							
			最大荷重 N	最大荷重 N			AWT	AUT						
AWT AUT BWT BUT	3-10	0.5	2.0	8.8	2.16	3.24	160	210						
	15		3.7	1.77										
	20		5.2	1.27										
	25		6.8	0.98										
	*30		8.5	0.78										
AWT AUT BWT BUT	4-15	0.6	4.0	11.1	2.55	2.16	180	220						
	20		6.4	1.37										
	25		8.4	0.98										
	30		10.9	0.78										
	*35		12.4	0.69										
	*40		15.0	0.57										
AWT AUT BWT BUT	5-15	0.8	2.9	20.79	5.1	5.39	190	230						
	20		4.6	3.43										
	25		6.4	2.45										
	30		8.4	1.86										
	35		10.0	1.57										
	*40		11.4	1.38										
	*45		13.3	1.18										
	*50		15.2	1.03										
	AWT BWT AUT BUT		6-20	1.0					3.7	33.15	8.6	6.57	200	240
			25						5.3	4.61				
30		6.9	3.53											
35		8.3	2.94											
40		10.0	2.45											
*45		10.8	2.27											
AWT BWT AUT BUT	8-25	1.2	5.3	41.19	9.81	5.88	210	250						
	30		7.3	4.31										
	35		9.1	3.43										
	40		11.9	2.65										
	45		13.6	2.35										
	50		15.5	2.06										
	*55		16.8	1.87										
	*60		18.8	1.67										
	*65		20.6	1.52										
	*70		22.8	1.38										
AWT BWT AUT BUT	10-30	1.6	5.2	77.47	20.59	10.89	250	290						
	35		6.8	8.34										
	40		8.4	6.77										
	45		10.0	5.69										
	50		11.6	4.9										
	55		13.2	4.31										
	60		15.2	3.73										
	*65		17.0	3.35										
	*70		19.3	2.95										
	*75		20.7	2.75										
*80	24.1	2.36												
*90	26.3	2.16												
*100	29.0	1.96												

◎初張力・ばね定数は参考値です。ロットによって多少のばらつきがあります。
荷重(kgf) = 荷重N × 0.101972
●巻数の算出方法(参考値):
総巻数 = [L - 2(D - d)] ÷ d
有効巻数 = 総巻数 - 2
※巻数は参考値です。ロットによって多少のばらつきがあります。

Type	D-L	線径 dmm	動荷重の場合	初張力 N (参考値)	ばね定数 N/mm (参考値)	¥基準単価			
			最大荷重 N			AWT			
AWT BWT AUT BUT	12-40	2.0	6.6	120.62	34.3	290			
	45		7.7	11.18					
	50		9.4	9.22					
	55		10.5	8.24					
	60		12.1	7.16					
	65		13.1	6.57					
	70		14.9	5.79					
	75		16.0	5.39					
	80		17.6	4.9					
	*90		19.1	4.52					
AWT	14-40	2.3	5.8	154.95	45.11	310			
	45		7.0	15.59					
	50		8.4	13.14					
	55		9.6	11.47					
	60		10.9	10.1					
	65		12.9	8.53					
	70		14.2	7.75					
	75		15.3	7.16					
	80		16.7	6.57					
	90		18.6	5.91					
AWT	16-50	2.6	7.5	195.15	55.9	350			
	55		9.0	15.49					
	60		10.4	13.34					
	65		11.9	11.67					
	70		13.4	10.4					
	75		15.0	9.32					
AWT	18-55	2.9	8.3	236.34	68.65	410			
	60		10.0	16.67					
	65		11.6	14.71					
	70		12.5	13.44					
	75		14.1	11.77					
	80		15.8	10.79					
	90		18.4	9.12					
	100		21.6	7.75					
	125		27.1	6.19					
	150		34.2	4.90					
AWT	20-60	3.2	9.2	281.45	82.38	500			
	70		11.9	16.67					
	80		14.7	13.53					
	90		17.5	11.38					
	100		20.1	9.9					
	125		27.8	7.16					
	150		33.8	5.89					
	175		40.6	4.90					
	AWT		24-80	4.0	11.7		430.51	123.6	760
			90		13.7		22.46		
100		16.6	18.63						
125		22.5	13.63						
150		28.5	10.79						
175		34.4	8.92						

37 型名: AWT10-50

Order 注文例
Delivery 出荷日

型式: AWT10-50

在庫品 翌日出荷 P.133
◎ご希望によりPM6:00迄、当日出荷受付致します。

●D8以下
大口 +6 日日出荷 数量 200~400

●D10以上
大口 +9 日日出荷 数量 200~400