

WELDED STAND PLATES -SHAPE STEEL TYPE-

溶接スタンド

一形鋼タイプ

☑カタログ規格外品はこちら P.137 ☑CADデータフォルダ名: 32_Ribs_and_Angle_Plates

■特長: 一形鋼タイプの溶接スタンドです。追加加工で高さ公差を変更できます。

Type		材質	表面処理
穴無しタイプ	穴位置指定タイプ	SS400	四三酸化鉄皮膜 無電解ニッケルメッキ
YSSTC	YSCT		
YSSTB	YSST		
YSSTM	YSMT		
-	YSFT	SUS304	-

☑SS400の四三酸化鉄皮膜に関しては、溶接部周辺が赤茶色になる可能性がございます。

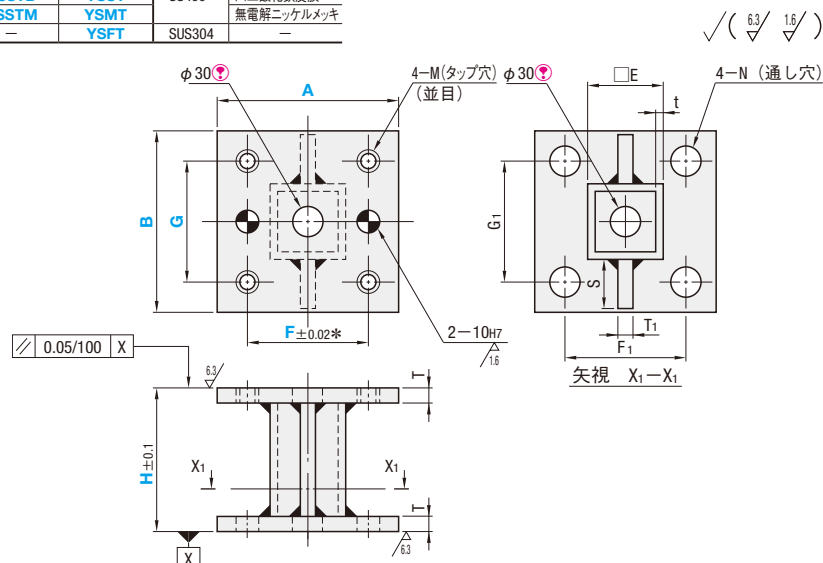

☑φ30穴は、穴無しタイプ・穴位置指定タイプ共通です。☑*公差はDh7穴に適用します。

RoHS10

穴無しタイプ

型式	Type	A	B	H 選択	T	T1	E	t	S	¥基準単価																			
										YSSTC			YSSTB			YSSTM													
										H100	H150 H200	H250 H300	H100	H150 H200	H250 H300	H100	H150 H200	H250 H300											
YSSTC YSSTB YSSTM	100	100	100	100	10	9	50	3.2	22	4,790	5,840	6,770	5,380	6,450	7,510	6,240	8,020	9,680											
			120	150															32	5,150	6,200	7,370	5,740	6,830	8,110	6,600	8,390	10,280	
			150	200															44	5,600	6,620	8,350	6,400	7,450	9,400	7,060	8,800	11,260	
			125	120															75	19	5,680	6,640	8,420	6,480	7,550	9,490	7,500	9,190	11,700
			150	150																32	7,840	9,880	11,750	8,800	10,980	13,000	9,660	12,420	15,020
			200	200															14	12	100	44	10,200	12,530	14,440	11,400	13,890	15,940	12,020

穴位置指定タイプ

型式	Type	A	B	H 選択	指定1mm単位		T	T1	E	t	S	F1	G1	M	N	¥基準単価											
					G	F										YSCT			YSST			YSMT			YSFT		
					H100	H150 H200										H250 H300	H100	H150 H200	H250 H300	H100	H150 H200	H250 H300	H100	H150 H200	H250 H300		
YSCT YSST YSMT YSFT	100	100	100	100	30~80	70~80	10	9	50	3.2	22	80	100	M10	11	5,200	6,300	7,320	5,800	6,960	8,110	6,360	8,040	9,640	7,690	9,320	10,840
																5,570	6,690	7,920	6,200	7,380	8,750	6,730	8,440	10,250	8,240	9,910	11,740
																6,110	7,190	9,120	6,920	8,040	10,150	7,280	8,930	11,440	9,040	10,640	13,500
																6,180	7,210	9,150	6,990	8,160	10,250	7,640	9,250	11,760	9,150	10,690	13,540
																8,510	10,690	12,700	9,510	11,860	14,040	9,960	12,720	15,320	12,600	15,830	18,800
																11,040	13,540	14,880	12,300	15,000	16,480	12,490	15,580	17,500	16,350	20,040	22,040
	100	120	100	150	30~100	70~80	10	9	50	3.2	22	80	100	M10	11	5,200	6,300	7,320	5,800	6,960	8,110	6,360	8,040	9,640	7,690	9,320	10,840
																5,570	6,690	7,920	6,200	7,380	8,750	6,730	8,440	10,250	8,240	9,910	11,740
																6,110	7,190	9,120	6,920	8,040	10,150	7,280	8,930	11,440	9,040	10,640	13,500
																6,180	7,210	9,150	6,990	8,160	10,250	7,640	9,250	11,760	9,150	10,690	13,540
																8,510	10,690	12,700	9,510	11,860	14,040	9,960	12,720	15,320	12,600	15,830	18,800
																11,040	13,540	14,880	12,300	15,000	16,480	12,490	15,580	17,500	16,350	20,040	22,040

Order 注文例: 型式 - B - H - G - F (HKC) YSSTB100 - B150 - H300 YSST150 - B150 - H200 - G100 - F95

Alteration 追加加工: 5 日目出荷 ☒ ストック不可

Delivery 出荷日: 5 日目出荷

☑注文締切: 3 日目出荷 500円/1本 PM 8:00迄 P.134

☑3本以上で1明細行当たり一律1,350円

Price 価格: 数量スライド価格 (☑1円未満切り捨て) P.133

数量区分	標準対応	個別対応
数量	1~19	20~50
値引率	基準単価	5%
		お見積り

☑表示数量超えはWOSにてご確認ください。

Alteration	Code	Spec.	¥/1Code
	HKC	H寸法の公差をH±0.05に変更します。 指定方法 HKC	1,000

WELDED STAND PLATES -SHAPE STEEL TYPE-

溶接スタンド

一形鋼高さ指定タイプ

☑カタログ規格外品はこちら P.137 ☑CADデータフォルダ名: 32_Ribs_and_Angle_Plates

■特長: 左ページで高さ・取付穴ピッチが合わない際は、こちらの規格で自由にお選び頂けます。

Type	材質	表面処理
YSCFT	SS400	四三酸化鉄皮膜 無電解ニッケルメッキ
YSSFT		
YSMFT		
-		

☑SS400の四三酸化鉄皮膜に関しては、溶接部周辺が赤茶色になる可能性がございます。

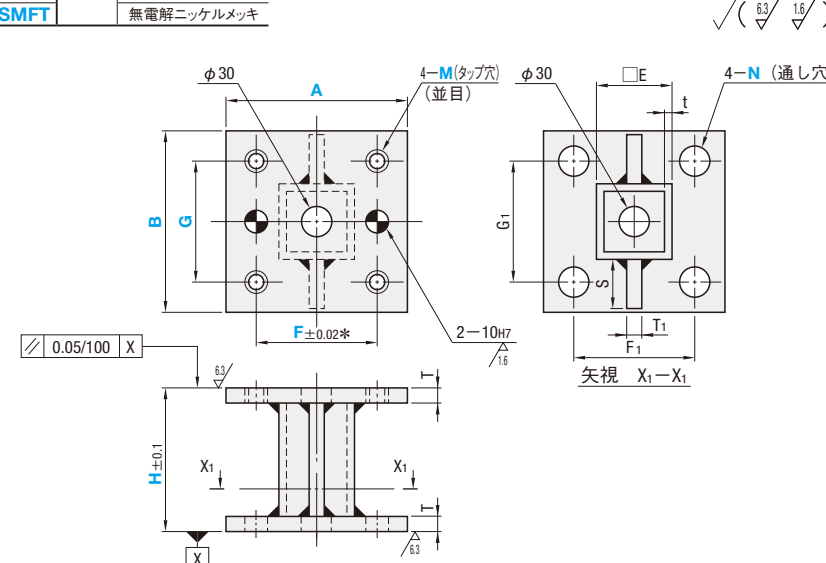

☑*公差はDh7穴に適用します。

RoHS10

型式	Type	A	B	指定1mm単位			選択		T	T1	E	t	S	F1	G1							
				H	G	F	M (タップ穴)	N (通し穴)														
YSCFT YSSFT YSMFT	100	100	100	100~300	30~80	70~80	8	9	10	9	50	3.2	22	80	100							
			120		30~100																	
			150		30~130	10										12						
			125		30~100												95~100					
			150		30~120	95~120										14	12	75	4.5	19	100	100
			200		30~170	120~170																

Order 注文例: 型式 - B - H - G - F - M - N YSCFT100 - B150 - H251 - G80 - F74 - M8 - N11

Delivery 出荷日: 5 日目出荷

Price 価格: 数量スライド価格 (☑1円未満切り捨て) P.133

数量区分	標準対応	個別対応
数量	1~9	10~20
値引率	基準単価	5%
		お見積り

☑表示数量超えはWOSにてご確認ください。

Alteration	Code	Spec.	¥/1Code
	HKC	H寸法の公差をH±0.05に変更します。 指定方法 HKC	1,000

A	B	H 指定1mm単位	¥基準単価		
			YSCFT	YSSFT	YSMFT
100	100	100~150	7,900	9,900	10,380
		151~200	8,660	11,060	11,320
		201~250	9,360	12,160	11,360
		251~300	10,060	13,260	11,380
		100~150	8,440	10,440	11,040
		151~200	9,200	11,600	12,000
100	120	100~150	10,060	12,860	13,120
		151~200	10,900	14,100	14,220
		201~250	9,140	11,140	12,160
		251~300	9,880	12,280	13,060
		100~150	11,220	14,020	14,780
		151~200	12,540	15,740	16,500
100	150	100~150	9,220	11,620	12,320
		151~200	9,920	12,720	13,260
		201~250	11,260	14,460	14,960
		251~300	12,580	16,180	16,660
		100~150	13,200	15,600	17,380
		151~200	14,700	17,500	19,280
100	200	100~150	16,080	19,280	21,060
		151~200	17,460	21,060	22,820
		201~250	16,900	19,300	22,200
		251~300	18,620	21,420	24,380
		100~150	19,540	22,740	26,180
		151~200	20,460	24,060	27,980

32 リブ・イケール 溶接スタンド