

SPUR GEARS -PRESSURE ANGLE20° MODULE 0.5/0.8/1.0/1.5/2.0/2.5/3.0 BTYPE Circular hole Fixed type-

# 平歯車

-圧力角20° モジュール0.5/0.8/1.0/1.5/2.0/2.5/3.0 B形状 軸穴固定タイプ-



締結部材						他			
回転軸	片持ちピン	メカロック	平行キー	ベアリングホルダ	ベアリング	セットカラー			
P.1-843	P.1-907	P.1-1573	P.1-285	P.1-953	P.1-1025	P.1-303			
P.1-906	P.1-932	P.1-1582	P.1-290	P.1-1020	P.1-1057	P.1-336			

CADデータフォルダ名: 20\_Gears

■特長: 平歯車軸穴指定タイプ(GEAHBB)に比べて、最大76%のプライスダウン、在庫化により翌日出荷を実現した商品です。

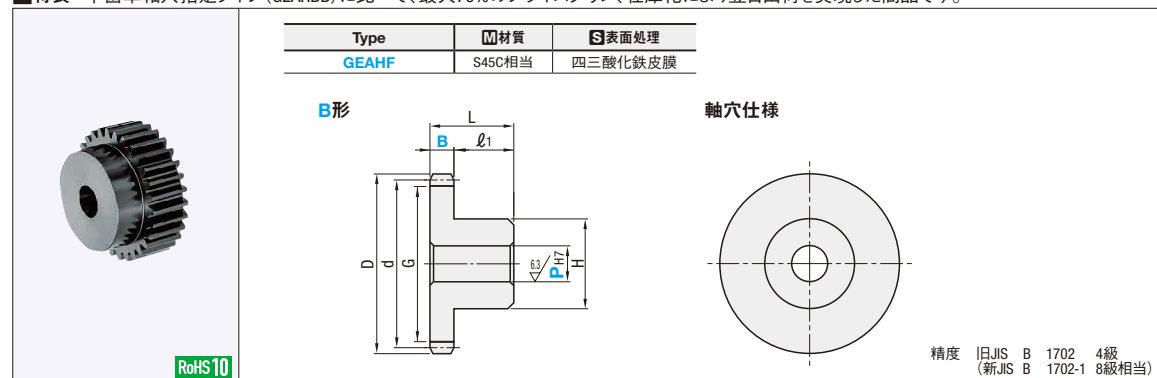

■モジュール 0.5/0.8/1.0(軸穴フリー寸法品はP.1597~P.1605、歯幅・ボス寸法の変更はP.1623をご参照下さい。)

型式	Type	モジュール	歯数	B	歯車形状	軸穴径PH7	d 基準円 直径	D 歯先円 直径	G 歯底円 直径	H	L	ℓ1	¥基準単価	
GEAHF	0.5	3	28	3	B	3	14	15	12.75	10	8	5	1,010	
			30				15	13.75	1,060					
			32				16	14.75	1,080					
			35				17.5	16.25	1,100					
			36				18	16.75	1,100					
			40				20	18.75	1,180					
		42	21	19.75	1,310									
		45	22.5	21.25	1,310									
		48	24	22.75	1,310									
		50	25	23.75	1,330									
		52	26	24.75	1,350									
		60	30	28.75	1,580									
	70	35	33.75	1,760										
	80	40	38.75	1,910										
	100	50	48.75	2,640										
	0.8	7	B	20	7	B	4	16	17.6	14	12.5	14	7	1,140
				24				19.2	20.8	1,220				
				25				20	21.6	1,300				
				28				22.4	24	1,370				
				30				24	25.6	1,440				
				32				25.6	27.2	1,490				
		36	28.8	30.4	1,780									
		40	32	33.6	1,980									
		45	36	37.6	2,190									
		48	38.4	40	2,330									
		50	40	41.6	2,470									
		1.0	12	B	20	12	B	6	20	22	17.5	30	20	10
	21				21				23	1,330				
	22				22				24	1,340				
	23				23				25	1,360				
	24				24				26	1,360				
	25				25				27	1,360				
	26		26	28	1,390									
	27		27	29	1,420									
	28		28	30	1,430									
	29		29	31	1,450									
30	30		32	1,590										
1.5	15		B	20	15	B	6	30	31	28.75	40	27	12	1,320
		21		31				29.75	1,330					
		22		32				30.75	1,340					
		23		33				31.75	1,360					
		24		34				32.75	1,360					
		25		35				33.75	1,360					
	26	36	34.75	1,390										
	27	37	35.75	1,420										
	28	38	36.75	1,430										
	29	39	37.75	1,450										
	30	40	38.75	1,590										
	2.0	20	B	22	20	B	8	22	24	19.5	20	20	8	1,360
23				23				25	1,360					
24				24				26	1,360					
25				25				27	1,360					
26				26				28	1,390					
27				27				29	1,420					
28		28	30	1,430										
29		29	31	1,450										
30		30	32	1,590										
2.5		25	B	20	25	B	8	20	22	17.5	41	16	16	1,320
				21				21	23	1,330				
				22				22	24	1,340				
	23			23				25	1,360					
	24			24				26	1,360					
	25			25				27	1,360					
	26	26	28	1,390										
	27	27	29	1,420										
	28	28	30	1,430										
	29	29	31	1,450										
	30	30	32	1,590										
	3.0	30	B	20	30	B	8	20	22	17.5	48	20	10	1,320
21				21				23	1,330					
22				22				24	1,340					
23				23				25	1,360					
24				24				26	1,360					
25				25				27	1,360					
26		26	28	1,390										
27		27	29	1,420										
28		28	30	1,430										
29		29	31	1,450										
30		30	32	1,590										

■モジュール 1.5/2.0/2.5/3.0(軸穴フリー寸法品はP.1607~P.1619、歯幅・ボス寸法の変更はP.1623をご参照下さい。)

型式	Type	モジュール	歯数	B	歯車形状	軸穴径PH7	d 基準円 直径	D 歯先円 直径	G 歯底円 直径	H	L	ℓ1	¥基準単価		
GEAHF	1.5	15	20	15	B	6	30	33	26.25	40	27	12	1,390		
			21				31.5	34.5	1,400						
			22				33	36	1,400						
			23				34.5	37.5	1,410						
			24				36	39	1,420						
			25				37.5	40.5	1,450						
			26				39	42	1,520						
			27				40.5	43.5	1,530						
			28				42	45	1,530						
			29				43.5	46.5	1,540						
			30				45	48	1,540						
			32				48	51	1,740						
		34	51	54	1,890										
		35	52.5	55.5	1,900										
		36	54	57	1,940										
		38	57	60	2,020										
		40	60	63	2,170										
		42	63	66	2,240										
		44	66	69	2,430										
		45	67.5	70.5	2,530										
		46	69	72	2,660										
		48	72	75	2,800										
		50	75	78	2,800										
		52	78	81	3,010										
		54	81	84	3,260										
		55	82.5	85.5	3,370										
		56	84	87	3,470										
		58	87	90	3,520										
		60	90	93	3,620										
		62	93	96	3,670										
		64	96	99	3,830										
		65	97.5	100.5	4,000										
		66	99	102	4,170										
		2.0	20	B	22	20	B	8	42	46	37	34	14	14	1,730
					23				44	48	39				1,850
					24				46	50	41				1,890
	25				48				52	43	1,890				
	26				50				54	45	1,970				
	27				52				56	47	1,970				
	28				54				58	49	2,240				
	29				56				60	51	2,270				
	30				58				62	53	2,340				
	32				60				64	55	2,430				
	34				64				68	59	2,600				
	35				68				72	63	2,730				
	36		70	74	65	2,800									
	38		72	76	67	2,900									
	40		76	80	71	3,300									
	42		80	84	75	3,410									
	44		84	88	79	3,550									
	45		88	92	83	3,790									
	46		90	94	85	4,020									
	48		92	96	87	4,320									
	2.5		25	B	20	25	B	8	50	55	43.75	41	16	16	2,400
					21				52.5	57.5	46.25				2,610
					22				55	60	48.75				2,680
					23				57.5	62.5	51.25				2,790
					24				60	65	53.75				2,870
					25				62.5	67.5	56.25				2,990
					26				65	70	58.75				3,120
					27				67.5	72.5	61.25				3,180
					28				70	75	63.75				3,330
					29				72.5	77.5	66.25				3,430
					30				75	80	68.75				3,460
					32				80	85	73.75				3,690
			34	85	90	78.75	3,740								
			35	87.5	92.5	81.25	3,970								
			36	90	95	83.75	4,090								
			3.0	30	B	20	30	B	8	60	66	52.5	48	18	18
		21				63				69	55.5	3,250			
		22				66				72	58.5	3,380			
		23				69				75	61.5	3,510			
		24				72				78	64.5	3,530			
		25				75				81	67.5	3,830			
		26		78	84	70.5	4,040								
		27		81	87	73.5	4,270								
		28		84	90	76.5	4,360								
		29		87	93	79.5	4,600								
		30		90	96	82.5	4,670								
		1.0		10	B	8	10	B	10	60	66	52.5	60	20	10
			61			67				53.5	4,670				
			62			68				54.5	4,770				
			63			69				55.5	4,880				
			64			70				56.5	5,130				
			65			71				57.5	5,200				
			66	72	58.5	5,270									
			67	73	59.5	5,300									
			68	74	60.5	5,330									
			69	75	61.5	5,360									
	70		76	62.5	5,390										
	71		77	63.5	5,420										
	72	78	64.5	5,450											

Order 注文例: 型式 GEAHF1.0 - 歯数 40 - B - 歯車形状 B - 軸穴径 8

Delivery 出荷日: 在庫品 翌日出荷 P.133

Price 価格: 数量スライド価格 (1円未満切り捨て) P.133

数量区分	標準対応			個別対応
	小口	大口	大口	大口
数量	1~9	10~14	15~30	31以上
値引率	35%	40%	45%	お見積り
出荷日	通常	+14日	お見積り	お見積り

☑表示数量超えはWOSIにてご確認ください。

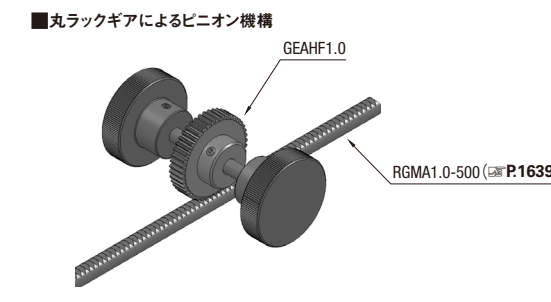

20  
歯  
車