



METAL FITTINGS FOR TIMING BELT DRIVES

タイミングベルト用金具

—ナット締めタイプ—

CADデータフォルダ名: 19_Timing_Pulleys

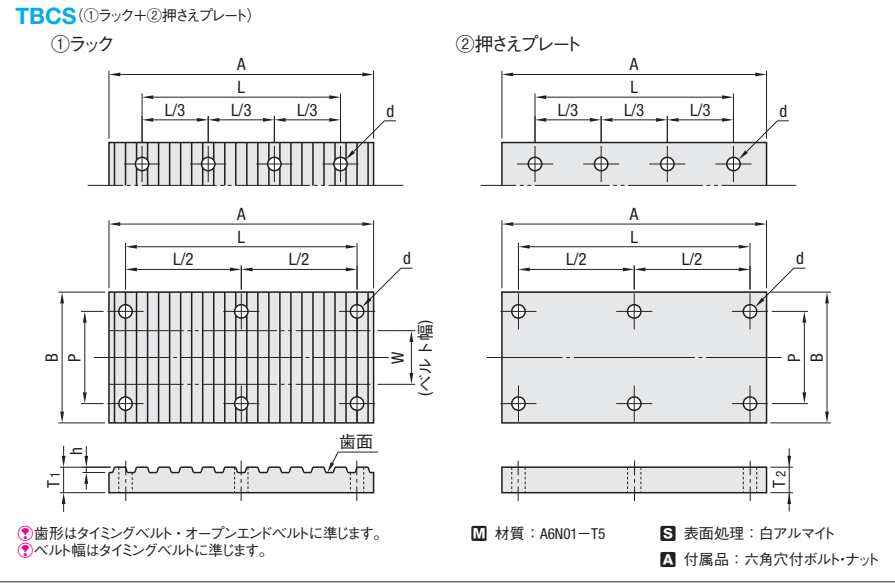
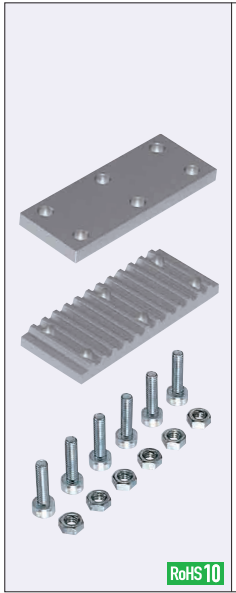

型式	ベルト種類	ベルト呼び幅	W	A	B	T ₁	T ₂	h	L	P	付属ボルト	d	取付穴数	¥基準単価	
TBCS (①+②)	MXL	019	4.8	26	16	4	4	0.51	19	10	M3-12	3.4	6	830	
		025	6.4		18					11					
		037	9.5		22					14					
	XL	050	12.7	26	66	24	6	1.25	56	18	M4-15	4.5	6	980	
		025	6.4	24		12									
		031	7.9	25		14									
	L	050	12.7	30	124	32	8	5	1.9	111	20	M5-20	5.5	8	990
		075	19.1	38		26									
		100	25.4	46		33									
	H	075	19.1	38	165	46	10	2.3	147	26	M5-20	5.5	8	1,280	
		100	25.4	46		33									
		150	38.1	58		45									
	S2M	200	50.8	70	26	70	4	0.76	18	58	M3-12	3.4	6	830	
		300	76.2	96		10									
		040	4	16		8									
	S3M	060	6	18	39	18	4	1.14	31	15	M3-12	3.4	6	860	
		100	10	24		10									
		060	6	18		10									
	S5M	100	10	28	65	22	6	1.81	51	14	M4-15	4.5	6	1,120	
		150	15	32		20									
200		20	36	20											
S8M	250	25	42	104	34	8	2.85	84	21	M5-20	5.5	8	1,200		
	150	15	34		22										
	250	25	44		32										
T5	300	30	50	65	50	6	1.2	51	37	M4-15	4.5	6	1,260		
	400	40	60		47										
	600	60	80		68										
T10	050	5	21	130	21	8	2.5	111	11	M5-20	5.5	8	1,270		
	100	10	26		16										
	150	15	32		21										
	200	20	38		38				26				1,310		
	250	25	43		31										
	150	15	34		22										
	200	20	40		40				27				1,350		
	250	25	44		32										
	300	30	50		37										
	050	5	21		21				11				1,380		
	100	10	26		16										
	150	15	32		21										
	200	20	38		38				26				1,580		
	250	25	43		31										
	150	15	34		22										
	200	20	40		40				27				1,100		
	250	25	44		32										
	300	30	50		37										

Ⓛ S□Mタイプの金具は、P□Mタイプのベルトにもご使用いただけます。

Ⓛ ベルトに取付穴をあけないでください。

Ⓛ A寸は6歯(金具)噛み合せの設定です。

Order 注文例

型式: TBCS - XL 025

Delivery 出荷日

在庫品 翌日出荷 P.133

ご希望によりPM6:00迄、当日出荷受付致します。

Price 価格

数量スライド価格 (Ⓛ1円未満切り捨て) P.133

数量区分	標準対応 小口	個別対応 大口
数量	1~9	10~14
値引率	5%	10%
出荷日	通常	お見積り

Ⓛ 表示数量超えはWOSIにてご確認ください。

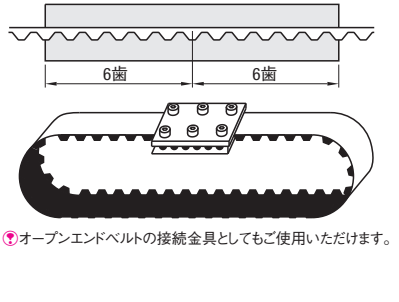

METAL FITTINGS FOR TIMING BELT DRIVES

タイミングベルト用金具

—下金具ショートタイプ—

CADデータフォルダ名: 19_Timing_Pulleys

■特長: 取り付ける部品に合わせて、穴位置を指定できるタイミングベルト用金具です。

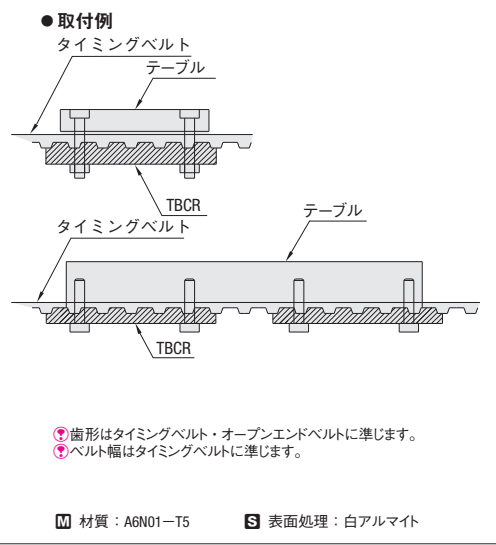
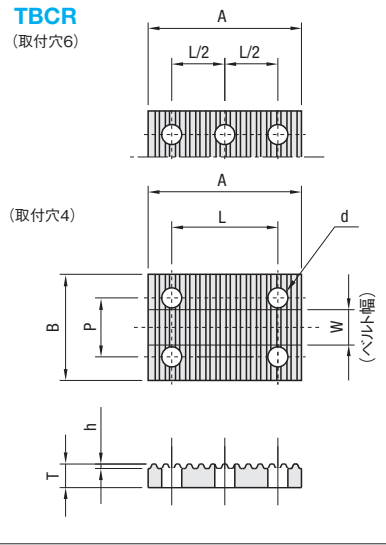
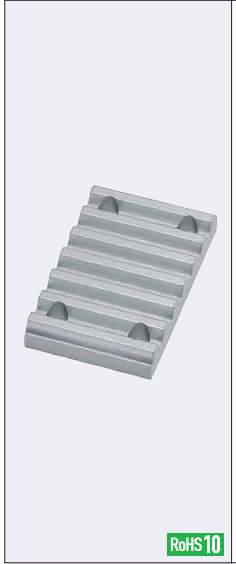

型式	ベルト種類	ベルト呼び幅	W	A	B	T	h	L	P	d	取付穴数	¥基準単価	
TBCR	XL	025	6.4	36	24	6	1.25	25	12	4.5	4	760	
		031	7.9		25				14				
		037	9.5		26				16				
	L	050	12.7	30	66	32	8	1.9	50	20	5.5	4	770
		075	19.1	38		26							
		100	25.4	46		33							
	H	150	38.1	58	89	58	10	2.3	70	46	5.5	6	1,000
		075	19.1	38		26							
		100	25.4	46		33							
	S3M	150	38.1	58	21	70	4	1.14	15	45	3.4	4	1,040
		200	50.8	80		58							
		300	76.2	96		85							
	S5M	060	6	20	35	20	6	1.81	25	11	4.5	4	880
		100	10	25		15							
		150	15	30		20							
	S8M	100	10	26	56	26	8	2.85	40	16	5.5	4	890
		150	15	32		21							
		200	20	36		26							
	T5	250	25	42	35	42	6	1.2	25	31	4.5	4	950
		150	15	34		22							
250		25	44	32									
T10	300	30	50	70	50	8	2.5	50	37	5.5	6	990	
	400	40	60		47								
	600	60	80		67								
	050	5	21		21				11			1,000	
	100	10	26		16								
	150	15	32		21								
	200	20	38		38				26			1,020	
	250	25	43		31								
	150	15	34		22								
	200	20	40		40				27			1,070	
	250	25	44		32								
	300	30	50		37								

Ⓛ S□Mタイプの金具は、P□Mタイプのベルトにもご使用いただけます。

Order 注文例

型式: TBCR - XL 025

Delivery 出荷日

在庫品 翌日出荷 P.133

ご希望によりPM6:00迄、当日出荷受付致します。

Price 価格

数量スライド価格 (Ⓛ1円未満切り捨て) P.133

数量区分	標準対応 小口	個別対応 大口
数量	1~9	10~14
値引率	20%	25%
出荷日	通常	お見積り

Ⓛ 表示数量超えはWOSIにてご確認ください。

