

CLAMPING HIGH TORQUE TIMING PULLEYS -S3M・S5M・S8M-

クランプハイトルクタイミングプーリー S3M・S5M・S8Mタイプ

■特長：ボルトを締めるだけで軸との締結が可能。位置合わせが容易になります。



- HTCPA □ □ S3M060
S3M100
(Pitch 3.0mm)
- HTCPA □ □ S5M100
S5M150
(Pitch 5.0mm)
- HTCPA □ □ S8M150
S8M250
(Pitch 8.0mm)

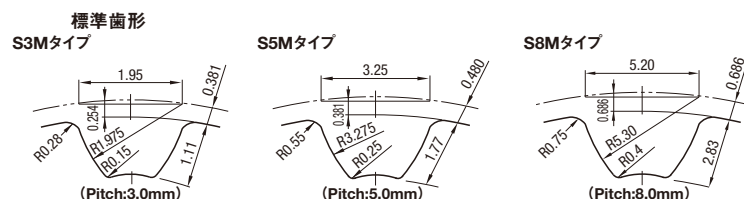
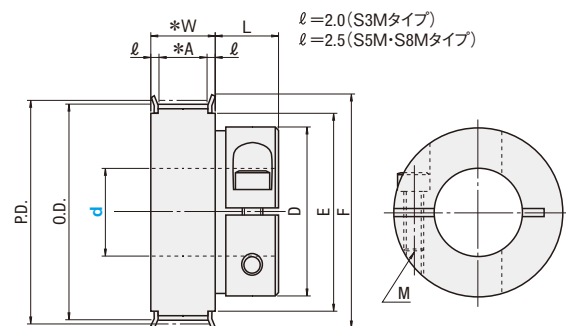

■推奨軸公差 h7 (g6)

⊙表面粗さはRa=3.2a以下に仕上げてください。

Type	材質	フランジ	表面処理
HTCPA	超々ジュラルミン系アルミ合金	アルミ合金	白アルマイト

*フランジカンメ済

*六角穴付ボルト付属 (SCM435・四三酸化鉄皮膜)

⊙軸穴に表面処理が付かない場合があります。歯溝寸法は歯数によって若干変わります。

■S3Mタイプ ■ハイトルクタイミングベルトは、P.1551をご参照ください。

Type	歯数	種類・呼び幅	d 選択	P.D.	O.D.	D	F	E	L	クランプボルト		¥基準単価	
										M	締付トルク (N・m)	S3M060	S3M100
HTCPA	24	S3M060 *A: 7 *W: 11	4	22.92	22.16	13	25	16	9	2	0.4	2,470	2,670
	26		4	24.83	24.07		28	18					
	28		4	26.74	25.98		30	20					
	30	S3M100 *A: 11 *W: 15	6 8	28.65	27.89	20	32	23	12.5	3	1.5	3,190	3,220
	32		6 8	30.56	29.80		35	25					
	36		6 8	34.38	33.62		40	28					
	40		8 10	38.20	37.44		44	32					
	44	8 10	42.02	41.25	31	48	36	14	4	3.5	3,650	3,700	
	48	8 10 11 12	45.84	45.07	33	50	38						
	50	8 10 11 12 13 14	47.75	46.98	36	52	40						
60	8 10 11 12 13 14 15 16	57.30	56.53	41	61	46	15.5						5

■S5Mタイプ ■ハイトルクタイミングベルトは、P.1551をご参照ください。

Type	歯数	種類・呼び幅	d 選択	P.D.	O.D.	D	F	E	L	クランプボルト		¥基準単価										
										M	締付トルク (N・m)	S5M100	S5M150									
HTCPA	24	S5M100 *A: 11 *W: 16	8 10	38.20	37.24	26	45	30	12.5	3	1.5	3,130	3,450									
	25		8 10	39.79	38.83		32	36														
	26		8 10	41.38	40.42		31	48						35								
	28		8 10	44.56	43.60	52		40														
	30		10	47.75	46.79	14		55	40													
	32		10 11 12 13 14	50.93	49.97		54.11	53.15														
	34		10 11 12 13 14 15 16	54.11	53.15		41	61	45													
	36		10 11 12 13 14 15 16	57.30	56.34	15.5		67	50													
	40		10 11 12 13 14 15 16 17 18 19	63.66	62.70			46	67	50												
	44		12 13 14 15 16 17 18 19	70.03	69.07		46	74	58	15.5	5	6	5,150	—	5,700	—						
	48		20 21 22 23 24			55	61.5	6	12								—	5,540	—	6,130		
	50		20 21 22 23 24 25			55	61.5	5	6								12	—	5,660	—	6,280	
	50		12 13 14 15 16 17 18 19	79.58	78.62	46	83	63	15.5	5	6	5,830	—	6,470	—							
	50		20 21 22 23 24 25			55	87	67								15.5	6	12	—	5,930	—	6,580
	60		12 13 14 15 16 17 18 19			95.49	94.53	46								99	80	15.5	5	6	7,390	—
	60		20 21 22 23 24 25	55	16.5			6	12	—	7,440	—	8,260									

■S8Mタイプ ■ハイトルクタイミングベルトは、P.1551をご参照ください。

Type	歯数	種類・呼び幅	d 選択	P.D.	O.D.	D	F	E	L	クランプボルト		¥基準単価		
										M	締付トルク (N・m)	S8M150	S8M250	
HTCPA	20	S8M150 *A: 17 *W: 22	12 13 14	50.93	49.56	36	58	40	14	4	3.5	5,880	7,010	
	22		12 13 14 15 16	56.02	54.65		41	61						45
	24		12 13 14 15 16 17 18 19	61.12	59.74		46	67						50
	25		12 13 14 15 16 17 18 19	63.66	62.29	70		56						
	28		15 16 17 18 19	71.30	69.93	55		80	60					
	30		20 21 22 23 24 25				16			5	6	8,160	9,800	
	30		15 16 17 18 19				16			5	6			
	30		20 21 22 23 24 25	17	6	12								
	32		S8M250	18 19	81.49	80.12	46	87	67	16	5	6	8,820	10,610
	32		20 21 22 23 24 25	17						6	12			
	34		18 19	16						5	6			
	34		20 21 22 23 24 25	86.58	85.21	46	95	75	17	6	12	9,550	11,520	
	34		18 19						16	5	6			
	36		20 21 22 23 24 25						17	6	12			
	36		18 19	91.67	90.30	46	99	80	16	5	6	10,390	12,540	
36	20 21 22 23 24 25	17	6						12					

■許容トルク (S3Mタイプ)

Type	歯数	軸径	許容トルク (N・m)
S3M	24 26 28	4	0.16
	30 32	6	0.95
		8	2.6
		8	0.95
	36	8	2.6
		8	2.6
		8	2.6
	40	8	2.6
		10	2.6
		10	2.6
	44	8	2.6
		10	2.6
		10	2.6
	48	8	2.6
		10	
		11	
12			
12			
12			
50	8	2.6	
	10		
	11		
	12		
	13		
	14		
60	8	2.6	
	10		
	11		
	12		
	13		
	15		

■許容トルク (S5Mタイプ)

Type	歯数	軸径	許容トルク (N・m)
S5M	24 25	8	2.6
		10	2.6
	26 28	8	2.6
		10	2.6
		10	2.6
	30	10	2.6
		11	
		12	
		13	
		14	
		14	
	32	10	2.6
		11	
		12	
		13	
		14	
		14	
	34 36	10	2.6
11			
12			
13			
14			
14			
40	10	2.6	
	11		
	12		
	13		
	14		
	15		
	16		
	16		
	17		
	18		
	18		
	19		
44 48 50 60	10	2.6	
	11		
	12		
	13		
	14		
	15		
	16		
	17		
	18		
	18		
	19		

■許容トルク (S8Mタイプ)

Type	歯数	軸径	許容トルク (N・m)
S8M	20	12	2.6
		13	7.6
		14	2.6
	22	12	7.6
		13	
		14	
		15	
		16	
		16	
	24 25	12	7.6
		13	
		14	
15			
16			
17			
28 30	15	7.6	
	16		
	17		
	18		
	19		
	20		
	21		
	22		
	23		
	24		
	25		
	32 34 36		18
19			
20			
21			
22			
23			
24			
25			
25			
25			
25			
25			

Order 注文例

型式: HTCPA40 - S3M060 - 10

軸穴径 d

Delivery 出荷日

3 日目出荷

Price 価格

■数量スライド価格 (⊙1円未満切り捨て) P.133

数量区分	標準対応			個別対応
	小口	大口	大口	
数量	1~9	10~14	15~19	20~30
値引率	基準単価	5%	10%	18%
出荷日	通常			お見積り

⊙表示数量超えはWOSにてご確認ください。