

規格追加
赤字表示

HOLDERS FOR SHAFT -MACHINING L-SHAPED-

シャフトホルダ -L型(機械加工品)-

-スタンダードタイプ・スリットタイプ-

大口
BIG ORDER

ステンレス・めっき品
脱脂洗浄サービス
対応商品詳細は下記URLへ
http://fa.misumi.jp

●特長：サイドにスペースがない場合に最適です。スタンダードタイプは最も安価、スリットタイプはシャフトを傷つけずに締結可能です。

●CADデータフォルダ名：02_Holders for Shaft

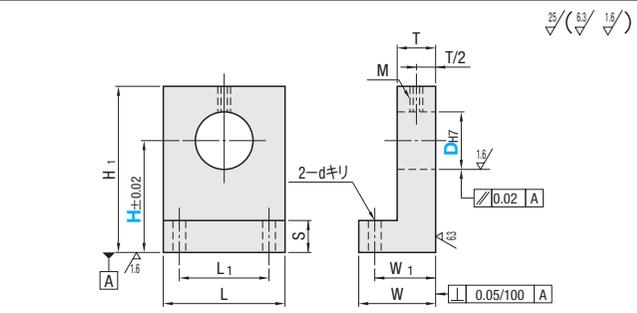

高さH選択タイプ	高さH指定タイプ	材質	S表面処理	A付属品
SHKLB	SHKLBH	S45C相当	四三酸化鉄皮膜	六角穴付止めねじ1本
SHKLM	SHKLMH	SUS304	無電解ニッケルメッキ	六角穴付止めねじ1本(SUS)
SHKLS	SHKLSH			
SHKLA	SHKLAH	アルミ合金	白アルマイト	

型式 Type	D	H		L	H ₁	T	S	W	W ₁	止めネジ M	L ₁	d	¥基準単価								
		高さH選択タイプ	高さH指定タイプ 0.1mm単位										高さH選択タイプ				高さH指定タイプ				
高さH選択タイプ SHKLB SHKLM SHKLS SHKLA	3	10 15 20	10.0~30.0	20	H+5	6	4	14	10	M3	10	3.6	SHKLB	SHKLM	SHKLS	SHKLA	SHKLBH	SHKLMH	SHKLSH	SHKLAH	
	4	10 15 20	15.0~35.0										H+6	1,220	1,260	1,490	870	2,510	2,570	2,830	1,780
	5	15 20 25											H+7	1,230	1,280	1,490	910	3,060	2,610	2,830	1,860
	6	15 20 25											H+8	1,300	1,340	1,570	970	3,730	2,730	2,960	1,990
	8	15 20 25 30 40											H+9	1,330	1,380	1,570	1,010	4,690	2,810	2,960	2,070
	10	20 25 30 40											H+10	1,490	1,540	2,490	1,170	5,210	3,140	4,720	2,400
高さH指定タイプ SHKLBH SHKLMH SHKLSH SHKLAH	12	20 25 30 40	20.0~50.0	25	H+11	8	6	18	13	M4	13	4.5	SHKLBH	SHKLMH	SHKLSH	SHKLAH	SHKLBH	SHKLMH	SHKLSH	SHKLAH	
	13	20 25 30 40											H+12	1,580	1,620	2,490	1,250	5,730	3,310	4,720	2,560
	16	20 25 30 40											H+13	1,670	1,720	2,660	1,330	6,250	3,520	5,020	2,730
	20	25 30 40 50 60											H+18	1,800	1,850	2,660	1,420	6,760	3,770	5,020	2,900
	25	30 40 50 60											H+20	1,900	1,940	2,730	1,540	7,290	3,970	5,150	3,110
	30	35 40 50 60											H+23	2,570	2,640	3,960	2,070	7,800	5,380	7,480	4,220
高さH指定タイプ SHKLBH SHKLMH SHKLSH SHKLAH	35	40 50 60 80	40.0~80.0	50	H+25	12	10	32	22	M6	30	9	SHKLBH	SHKLMH	SHKLSH	SHKLAH	SHKLBH	SHKLMH	SHKLSH	SHKLAH	
	40	40 50 60 80											H+26	2,710	2,790	4,080	2,210	8,340	5,700	7,700	4,510
	50	40 50 60 80											H+30	3,130	3,200	5,560	2,840	8,840	6,150	10,510	5,790
	60	40 50 60 80											H+38	3,420	3,500	6,640	3,160	9,370	7,530	12,550	6,450
	80	40 50 60 80											H+38	3,860	3,930	7,560	3,730	9,880	8,020	14,280	7,610
	100	40 50 60 80											H+38	5,080	5,150	9,810	4,780	10,400	10,500	18,530	9,750

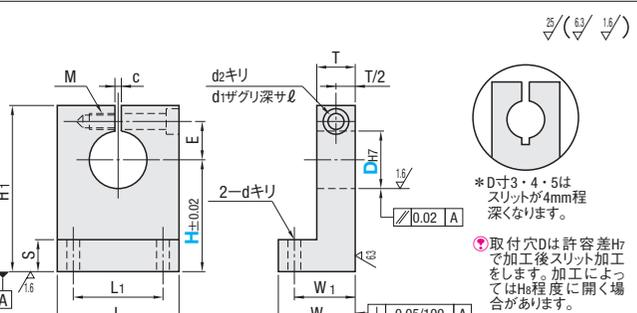

高さH選択タイプ	高さH指定タイプ	材質	S表面処理	A付属品
SHKSB	SHKSBH	S45C相当	四三酸化鉄皮膜	六角穴付ボルト1本
SHKSM	SHKSMH	SUS304	無電解ニッケルメッキ	六角穴付ボルト1本(SUS)
SHKSS	SHKSSH			
SHKSA	SHKSAH	アルミ合金	白アルマイト	六角穴付ボルト1本
SHKSD	-	アルミ合金	黒アルマイト	六角穴付ボルト1本

型式 Type	D	H		L	H ₁	T	S	W	W ₁	L ₁	d	E	締付ボルト M	d ₂	d ₁	l	C	¥基準単価									
		高さH選択タイプ	高さH指定タイプ 0.1mm単位															高さH選択タイプ				高さH指定タイプ					
高さH選択タイプ SHKSB SHKSM SHKSS SHKSA SHKSD	3	10 15 20	10.0~30.0	20	H+11	8	4	16	12	12	3.5	7	M3深6	3.5	6.5	3.5	1.5	SHKSB	SHKSM	SHKSS	SHKSA	SHKSBH	SHKSMH	SHKSSH	SHKSAH		
	4	10 15 20	15.0~35.0															H+12	1,450	1,490	2,030	1,070	1,220	2,980	3,060	3,830	2,190
	5	15 20 25																H+16	1,460	1,500	2,030	1,100	1,620	3,670	3,060	3,830	2,240
	6	15 20 25																H+16	1,490	1,540	2,090	1,120	2,040	4,350	3,140	3,950	2,280
	8	15 20 25 30 40																H+16	1,530	1,580	2,090	1,130	2,350	5,190	3,230	3,950	2,320
	10	20 25 30 40																H+18	1,610	1,660	3,150	1,230	3,040	5,740	3,390	5,950	2,520
高さH指定タイプ SHKSBH SHKSMH SHKSSH SHKSAH SHKSD	12	20 25 30 40	20.0~50.0	25	H+18	10	6	20	15	15	4.5	13	M4深8	4.5	8	4.5	2	SHKSBH	SHKSMH	SHKSSH	SHKSAH	SHKSBH	SHKSMH	SHKSSH	SHKSAH		
	13	20 25 30 40																H+20	1,610	1,660	3,150	1,230	3,340	6,290	3,390	5,950	2,520
	16	20 25 30 40																H+20	1,670	1,720	3,360	1,260	3,630	6,840	3,520	6,340	2,570
	20	25 30 40 50 60																H+28	1,670	1,720	3,360	1,280	3,920	7,390	3,520	6,340	2,610
	25	30 40 50 60																H+33	1,820	1,860	3,440	1,420	4,220	7,930	3,800	6,500	2,900
	30	35 40 50 60																H+38	2,470	2,510	4,980	1,990	4,530	8,480	5,130	9,400	4,050
高さH指定タイプ SHKSBH SHKSMH SHKSSH SHKSAH	35	40 50 60 80	40.0~80.0	50	H+33	20	10	40	30	30	9	27	M8深16	9	14	9	3	SHKSBH	SHKSMH	SHKSSH	SHKSAH	SHKSBH	SHKSMH	SHKSSH	SHKSAH		
	40	40 50 60 80																H+36	2,630	2,670	5,110	2,160	4,840	9,030	5,460	9,660	4,420
	50	40 50 60 80																H+38	3,030	3,080	6,420	2,740	5,130	10,130	6,280	12,120	5,580
	60	40 50 60 80																H+38	3,320	3,370	7,500	3,060	5,430	10,670	6,860	14,160	6,240
	80	40 50 60 80																H+38	4,170	4,210	8,400	3,730	5,730	11,240	8,600	15,860	7,610
	100	40 50 60 80																H+38	5,710	5,830	10,730	5,510	6,030	11,790	11,900	20,270	11,240

Order 注文

型式	H
SHKLM8	25
SHKLMH8	25.6
SF-SHKSS20	30

脱脂洗浄サービス P130

Delivery 出荷日

SHK□B・SHK□M・SHK□A	SHK□S・SHK□D
3 日目出荷	3 日目出荷

ストークA 翌日出荷 200円/1本 PM 3:00迄 P134
ストークB 翌日出荷 200円/1本 PM 6:00迄 P134

ストークA早割は1明細行当たり一律200円
ストークAは3本以上で1明細行当たり一律540円

規格追加
赤字表示

HOLDERS FOR SHAFT -MACHINING L-SHAPED-

シャフトホルダ -L型(機械加工品)-

-側方スリットタイプ・セパレートタイプ-

大口
BIG ORDER

ステンレス・めっき品
脱脂洗浄サービス
対応商品詳細は下記URLへ
http://fa.misumi.jp

●特長：サイドにスペースがない場合に最適です。側方スリットは全てのボルトを上から固定可能。セパレートはメンテナンスが容易です。

●CADデータフォルダ名：02_Holders for Shaft

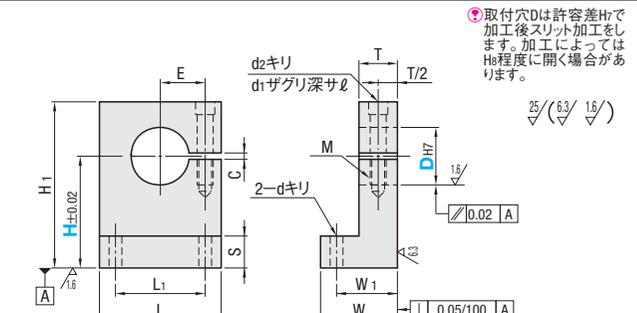

高さH選択タイプ	高さH指定タイプ	材質	S表面処理	A付属品
SHKWB	SHKWBH	S45C相当	四三酸化鉄皮膜	六角穴付ボルト1本
SHKWM	SHKWMH	SUS304	無電解ニッケルメッキ	六角穴付ボルト1本(SUS)
SHKWS	SHKWSH			
SHKWA	SHKWAH	アルミ合金	白アルマイト	六角穴付ボルト1本
SHKWD	-	アルミ合金	黒アルマイト	六角穴付ボルト1本

型式 Type	D	H		L	H ₁	T	S	W	W ₁	L ₁	d	E	締付ボルト M	d ₂	d ₁	l	C	¥基準単価									
		高さH選択タイプ	高さH指定タイプ 0.1mm単位															高さH選択タイプ				高さH指定タイプ					
高さH選択タイプ SHKWB SHKWM SHKWS SHKWA SHKWD	8	15 20 25 30 40	15.0~50.0	32	H+8	10	6	22	16	22	4.5	11	M4深8	4.5	8	4.5	2	SHKWB	SHKWM	SHKWS	SHKWA	SHKWBH	SHKWMH	SHKWSH	SHKWAH		
	10	20 25 30	20.0~50.0															H+9	1,700	1,750	3,360	1,460	2,490	2,180	3,770	6,340	2,820
	12	20 25 30																H+10	1,700	1,750	3,360	1,460	2,410	2,530	3,770	6,340	2,740
	13	20 25 30																H+11	1,760	1,810	3,600	1,510	2,550	2,710	3,890	6,800	2,880
	16	20 25 30 40																H+13	1,760	1,810	3,600	1,510	2,550	3,200	3,890	6,800	2,880
	20	25 30 40 50 60																H+15	1,920	1,960	3,690	1,670	2,850	3,680	4,220	9,970	3,240
高さH指定タイプ SHKWBH SHKWMH SHKWSH SHKWAH SHKWD	20	25 30 40 50 60	25.0~60.0	50	H+15	16	8	32	24	36	6.5	17	M6深12	6.6	11	6.5	2	SHKWBH	SHKWMH	SHKWSH	SHKWAH	SHKWBH	SHKWMH	SHKWSH	SHKWAH		
	25	30 40 50 60																H+18	2,600	2,650	5,270	2,250	3,890	4,260	5,690	9,950	4,400
	30	30 40 50 60																H+21	2,770	2,820	5,450	2,430	4,160	4,610	6,060	10,290	4,710
	35	40 50 60																H+24	3,200	3,240	7,000	2,830	4,880	4,950	6,960	13,230	5,530
	40	40 50 60																H+27	3,500	3,550	8,210	3,060	5,260	5,300	7,620	15,510	5,960
	50	40 50 60 80																H+27	4,390	4,440	9,240	3,830	6,590	5,650	9,540	17,470	7,470

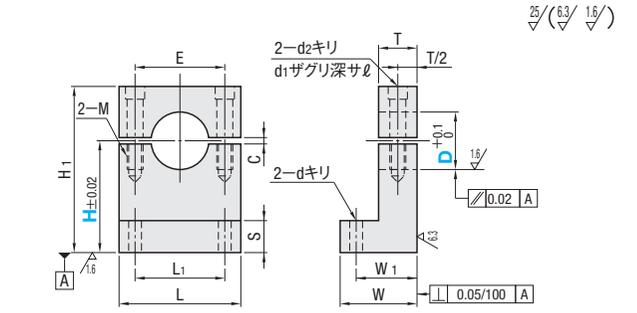

高さH選択タイプ	高さH指定タイプ	材質	S表面処理	A付属品
SHKPB	SHKPBH	S45C相当	四三酸化鉄皮膜	六角穴付ボルト2本
SHKPM	SHKPMH	SUS304	無電解ニッケルメッキ	六角穴付ボルト2本(SUS)
SHKPS	SHKPSH			
SHKPA	SHKPAH	アルミ合金	白アルマイト	六角穴付ボルト2本
SHKPD	-	アルミ合金	黒アルマイト	六角穴付ボルト2本

型式 Type	D	H		L	H ₁	T	S	W	W ₁	L ₁	d	E	締付ボルト M	d ₂	
------------	---	---	--	---	----------------	---	---	---	----------------	----------------	---	---	------------	----------------	--